

## Ingenious Pilot Plants

Ingenious Inc is a fast growing process solutions company with expertise in Process Consulting, Training Solutions, and Remote process monitoring. Since 2000, the company has been providing solutions to the oil & gas, petrochemicals, refining, & pharmaceutical industries. Our global presence along with depth of experience allows us to provide end-to-end solutions in a resource limited economy. We have over 150 clients globally, including several Fortune 500 companies. Our rapid growth and integrity have earned us a spot in the list of the 50 fastest growing technology companies in Houston for last 2 years.

Pilot plants are a key part of any R&D lab, University or Technical college. These pilot units can generate information about the behavior of the system for use in design of larger facilities or train operators on start-up, shutdown and operation of such units in the real world. Ingenious offers integrated turn-key pilot plants combined with our cutting edge tools in operator training simulators and our PRO-SCADA software; we can offer the best in class training and pilot system for your facility. Our highly experienced engineering professionals have extensive design, simulation, automation, fabrication and commissioning experience.



## Ingenious Turnkey Solutions



Ingenious Inc provides process design, simulation and engineering services for these pilot plants. In addition, Ingenious also deploys its next generation solution for Supervisory Control and Data Acquisition (SCADA) for monitoring and controlling the pilot plant. As an option, a custom or generic dynamic model of the pilot unit can be provided using our ProDyn training simulator. This would allow students to train on a real-time simulator before actually operating the pilot unit.

Ingenious connects the pilot plant to the PRO-SCADA software. PRO-SCADA allows users to view and control the plant in a user-friendly graphical interface- all in a single turn-key system.

Version: 02/26/2009

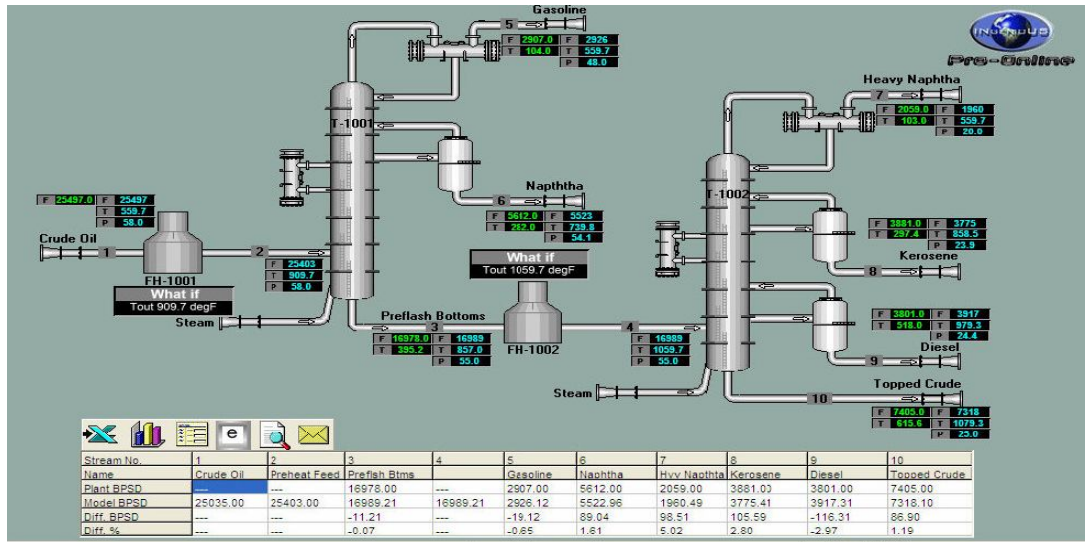

TYPICAL PRO-SCADA Graphic

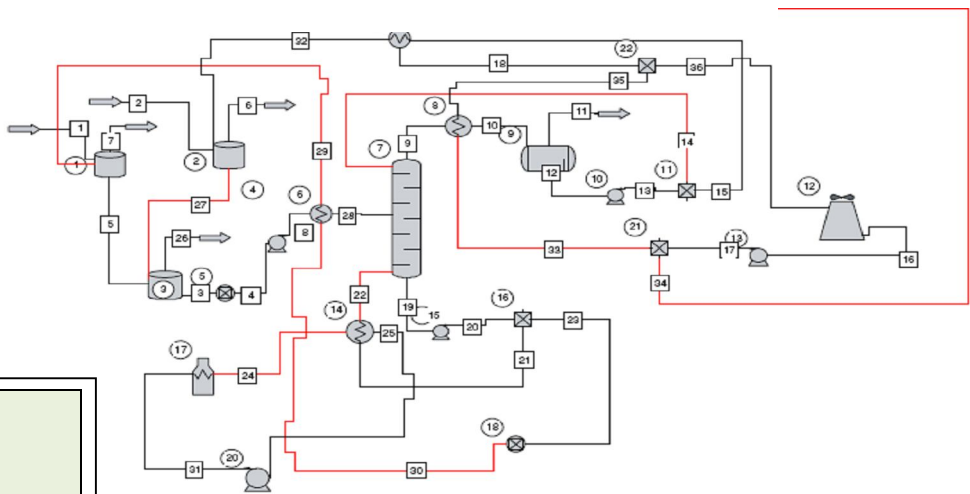

Pilot Plant Design in progress...

### Pilot Units Offered

- Distillation Unit
- Ion Exchange
- Liquid-Liquid Extraction
- Fixed Bed Reactor
- Heat Exchanger
- Reverse Osmosis
- Boiler/Furnace
- Other custom systems

### SOME OF OUR CLIENTS

Exxon, Reliance Industries, Suncor Energy, Shaw, Siemens, US Government, Valero Energy, Indian Oil Corporation, Indonesian Oil Academy, Jubail Industrial, KBR, Laffan Refinery, PETRONAS, etc.

Version: 02/26/2009

Office Address: 10700 Richmond Avenue, Suite108, Houston Texas.77042. USA. Tel No. : 832-242-0220 • Fax No.: 713-783-7449  
 Toll Free No.: 1-866-8INGENIOUS • Email: [Sales@ingeniousinc.com](mailto:Sales@ingeniousinc.com) • Website: [www.ingeniousinc.com](http://www.ingeniousinc.com)  
 Version Ingenious brochure -A 20081013